

# Devon&Devon

## THE THIRTIES

Design by **Pierre-Yves Rochon**

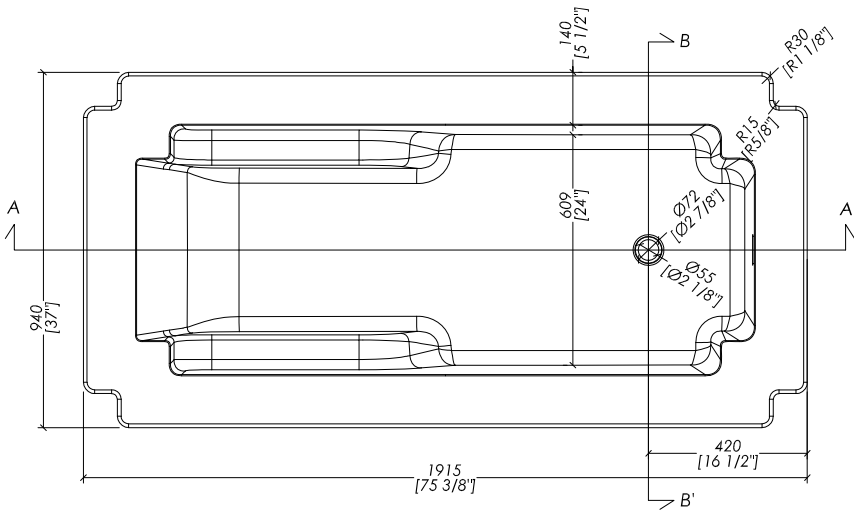

► OGNI VASCA È COMPRESIVA DI PILETTA CON COVER IN WHITE TEC PLUS E SIFONE (EACC571).  
 ► SE È RICHIESTA LA FORATURA, SPECIFICARE IL MODELLO DEL RUBINETTO (SOLO PRODOTTI DEVON&DEVON) E LA POSIZIONE

► DRAIN WITH COVER IN WHITE TEC PLUS AND SIPHONED TRAP ASSEMBLY INCLUDED (EACC571).  
 ► SHOULD YOU REQUIRE PRE-DRILLED HOLES FOR A DECK-MOUNTED TAP, PLEASE SPECIFY THE POSITION

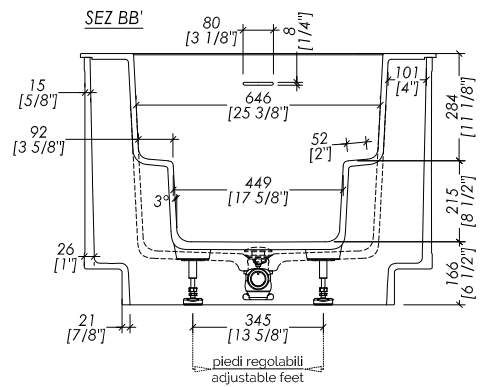
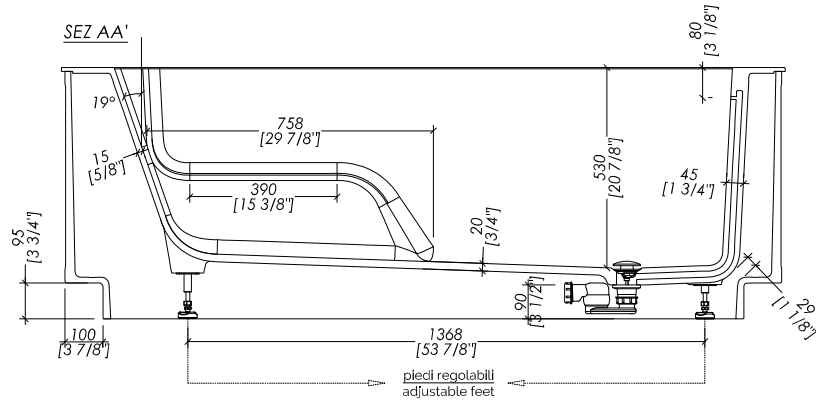
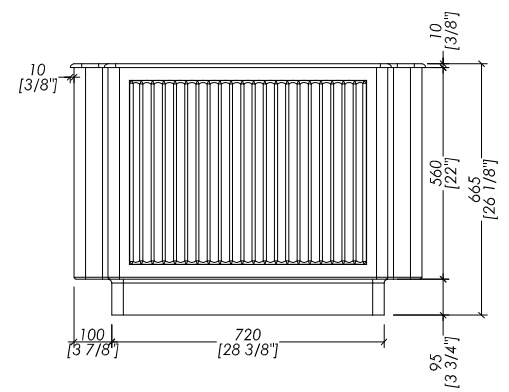
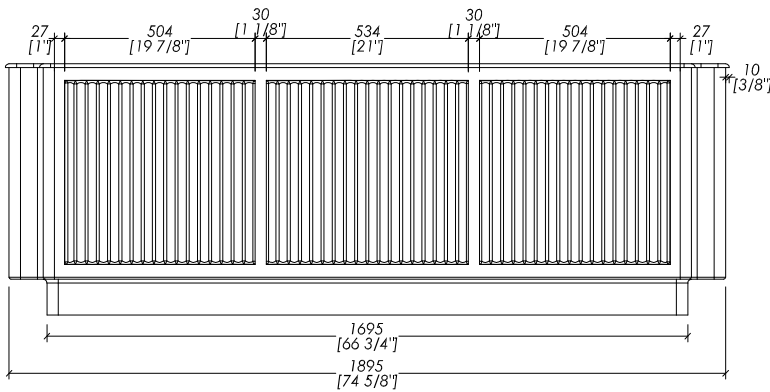

updating 01|2024

THIERTIES\_VA

► VASCA  
 MATERIALE: white tec plus  
 FINITURA: bianca opaca  
 ► TOLLERANZA: ± 8mm  
 ► DIMENSIONE IMBALLO: mm 2000x1180x885 H  
 ► PESO NETTO: 79 (invaso) + 93 (guscio esterno) = 172 Kg  
 ► PESO LORDO: 223 Kg  
 ► VOLUME: 374 L ► considerando il limite di capienza al troppopieno

N.B. Tutte le misure sono in millimetri/pollici. Questo disegno è di proprietà Devon&Devon. Non può essere riprodotto o trasmesso a terzi senza autorizzazione.

► BATHTUB  
 MATERIAL: white tec plus  
 FINISH: white matt  
 ► TOLERANCE: ± 3/8"  
 ► PACKAGING SIZE: inch 74 1/4"x 40 3/8"x 34 7/8" H  
 ► NET WEIGHT: 174 (bathtub) + 205 (shell) = 379 Lbs  
 ► GROSS WEIGHT: 492 Lbs  
 ► VOLUME: 98.8 Gal ► considering the capacity of the water to the overflow

N.B. All measurements are in millimetres/inch. This drawing is property of Devon&Devon. It may not be reproduced or transmitted to third parties without authorization.