

Devon&Devon

CUBE

design Ufficio Stile

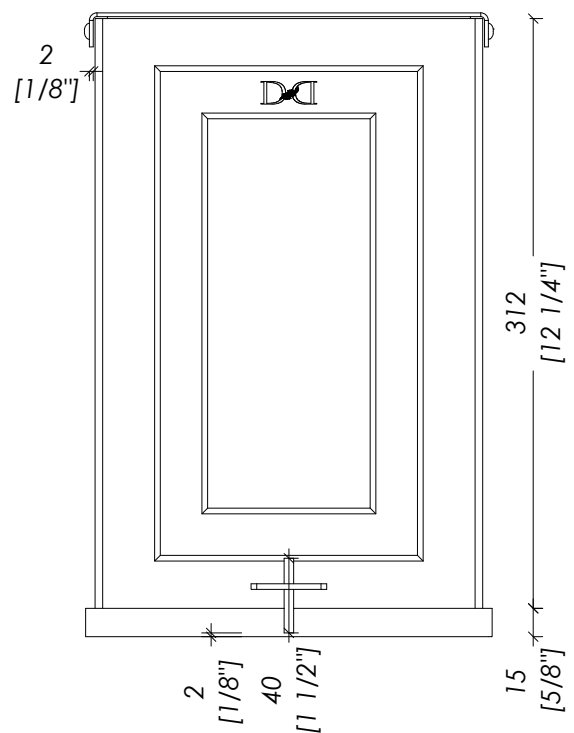
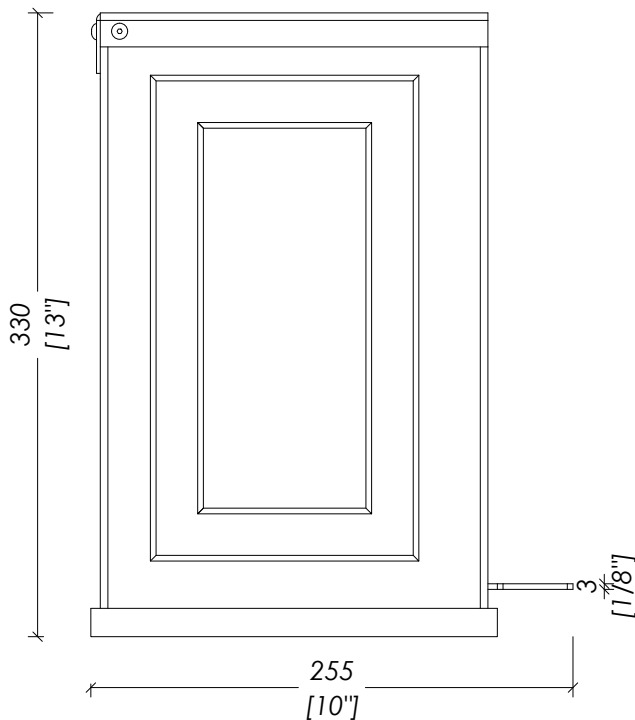
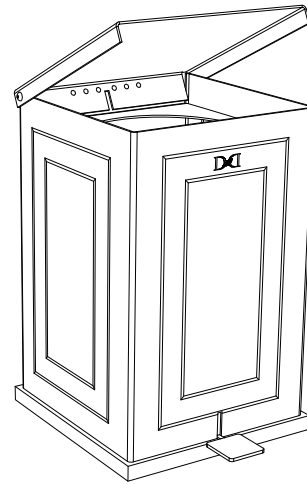
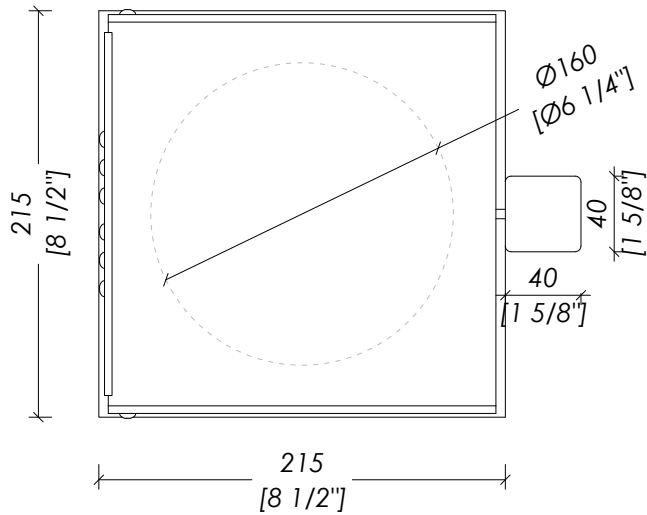

updating 02|2024

CUBE305CR; CUBE305OT; CUBE305BR; CUBE305NK

- > CESTINO CON PEDALE
- > MATERIALE: ottone
- > FINITURA: cromo, oro chiaro, bronzo, nickel lucido
- > TOLLERANZA: $\pm 2\%$
- > DIMENSIONE IMBALLO: mm 320x320x340H
- > PESO: 7,5 Kg

N.B. Tutte le misure sono in millimetri/pollici. Questo disegno è di proprietà Devon&Devon. Non può essere riprodotto o trasmesso a terzi senza autorizzazione.

- > PEDAL-OPERATED WASTE BASKET
- > MATERIAL: brass
- > FINISH: chrome, light gold, bronze, polished nickel
- > TOLERANCE: $\pm 2\%$
- > PACKAGING: inch 12 5/8"x12 5/8"x13 3/8"H
- > WEIGHT: 16,5 Lbs

N.B. All measurements are in millimetres/inches. This drawing is property of Devon&Devon. It may not be reproduced or transmitted to third parties without authorization.