

Devon&Devon

ETOILE MEDIUM CONSOLE

design **Ufficio Stile**

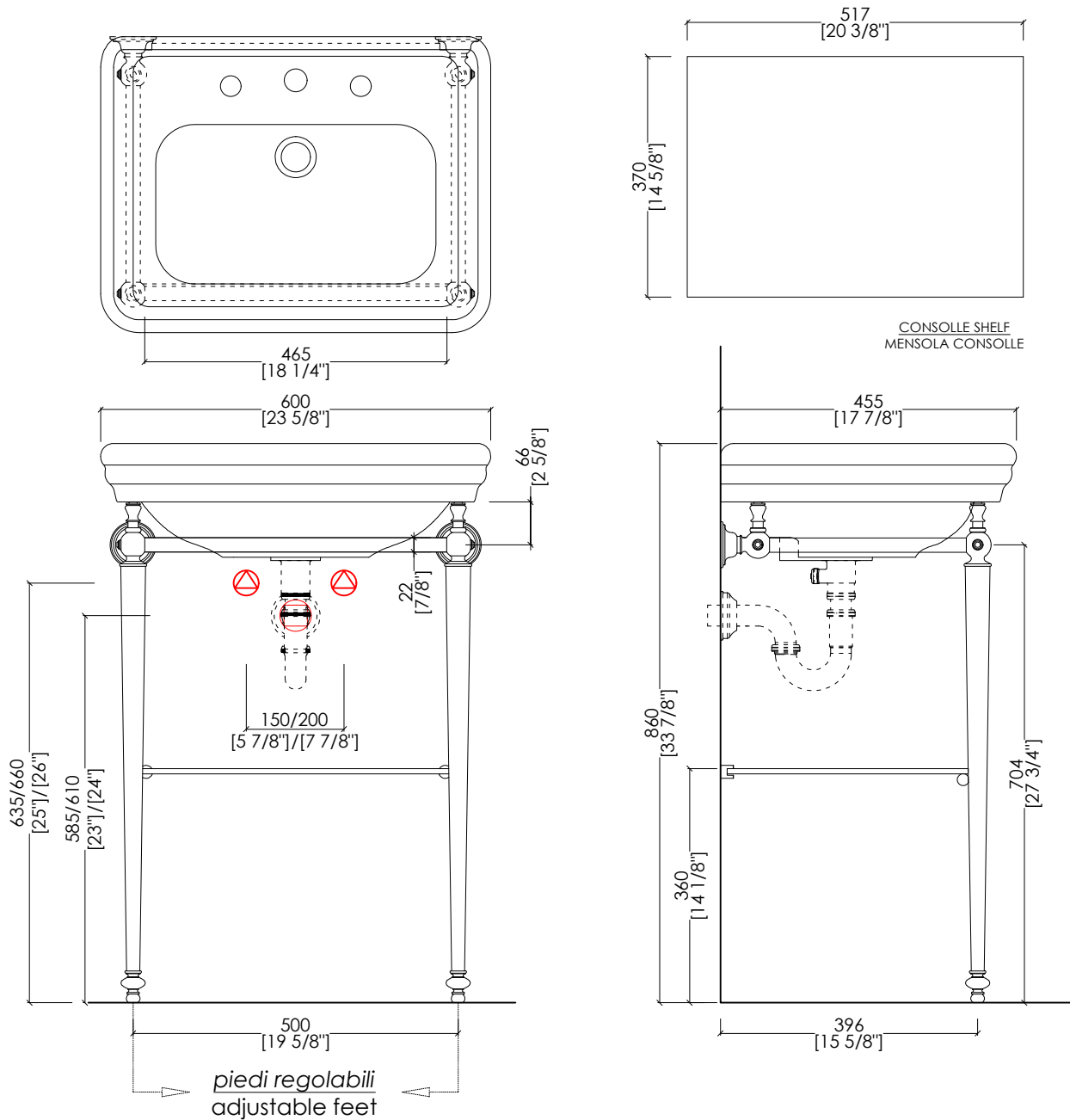

 PREDISPOSIZIONE PER ADDUZIONE ACQUA

 POSITION FOR WATER INLET

 PREDISPOSIZIONE PER SIFONE 325/321

 POSITION FOR SIPHON 325 /321

updated **01|2025**

DEETOILEMD(1-3)F_CR; DEETOILEMD(1-3)F_OT; DEETOILEMD(1-3)F_NK; DEETOILEMD(1-3)F_BR

> STRUTTURA:

MATERIALE > ottone

FINITURA: cromo | oro chiaro | nickel lucido | bronzo

> RIPIANO:

MATERIALE > vetro trasparente extra chiaro temperato 8 mm

> LAVABO ETOILE MEDIO:

MATERIALE > ceramica

FINITURA: bianco

> DIMENSIONI IMBALLO: mm 850x660x145H

> PESO TOTALE: 12 Kg

> STRUCTURE:

MATERIAL > brass

FINISH: chrome | light gold | polished nickel | bronze

> SHELF:

MATERIAL > 8 mm extra clear tempered glass

> ETOILE MEDIUM BASIN:

MATERIAL > ceramic

FINISH: white

> PACKAGING SIZE: inch 33 1/2"x 26"x 5 3/4"H

> TOTAL WEIGHT: 26.5 Lbs

N.B. Tutte le misure sono in millimetri/pollici. Questo disegno è di proprietà Devon&Devon. Non può essere riprodotto o trasmesso a terzi senza autorizzazione.

N.B. All measurements are in millimetres/inch. This drawing is property of Devon&Devon. It may not be reproduced or transmitted to third parties without authorization.

Devon&Devon

ETOILE MEDIUM CONSOLE

design **Ufficio Stile**

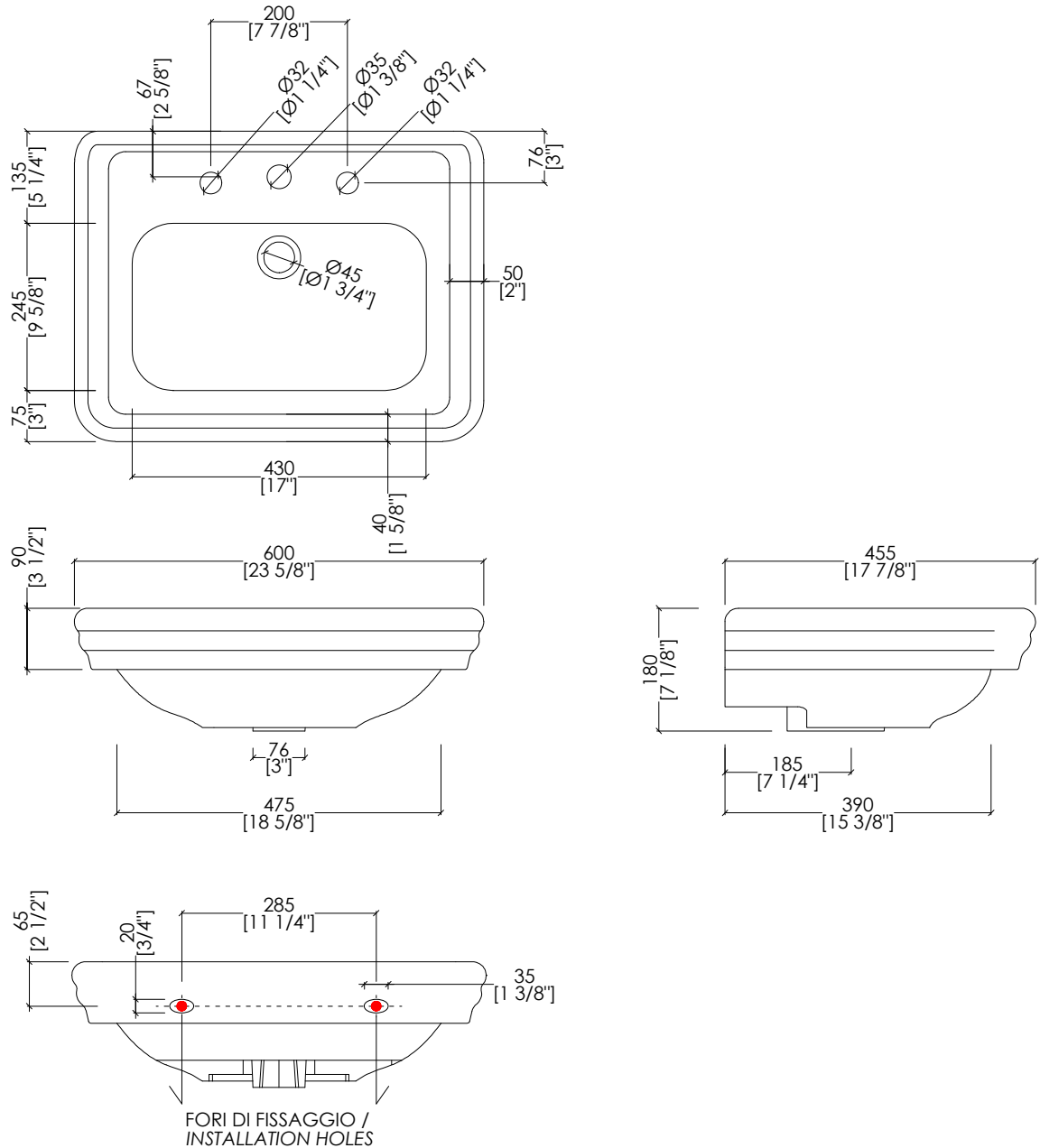

updating 01|2025

IBLM(1-3)FET

- > LAVABO MEDIO (1-3 FORI)
- > MATERIALE: ceramica
- > FINITURA: bianco o nero
- > TOLLERANZA: $\pm 2\% \geq 750$ mm; $\pm 5\% \leq 750$ mm
- > DIMENSIONE IMBALLO: mm 630x290x500H
- > PESO: 14 Kg

- > MEDIUM BASIN (1-3 TAP HOLES)
- > MATERIAL: ceramic
- > FINISH: white or black
- > TOLERANCE: $\pm 2\% \geq 29 1/2$ " inch; $\pm 5\% \leq 29 1/2$ " inch
- > PACKAGING SIZE: inch 24 3/4"x 11 3/8"x 19 5/8"H
- > WEIGHT: 30.9 Lbs

N.B. Tutte le misure sono in millimetri/pollici. Questo disegno è di proprietà Devon&Devon. Non può essere riprodotto o trasmesso a terzi senza autorizzazione.

N.B. All measurements are in millimetres/inch. This drawing is property of Devon&Devon. It may not be reproduced or transmitted to third parties without authorization.