

Devon&Devon

DOUBLE SEASON

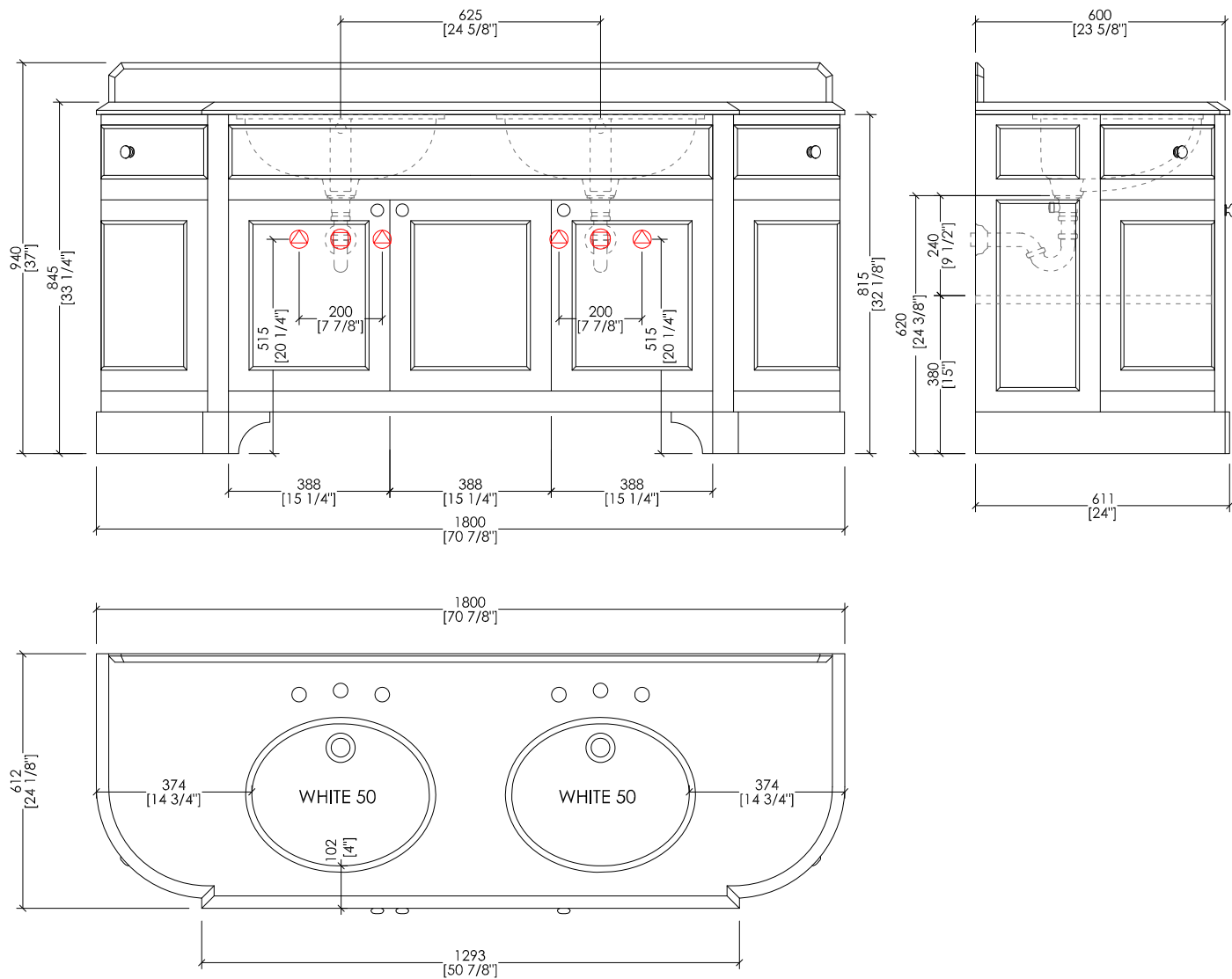

* MISURE CON SIFONE DDA325

 PREDISPOSIZIONE PER ADDUZIONE ACQUA

 PREDISPOSIZIONE PER SIFONE

* MEASUREMENTS WITH DDA325 S-TRAP

 POSITION FOR WATER INLET

 POSITION FOR SIPHON

updating 01|2023

> MOBILE:

MATERIALE > legno laccato
 FINITURA: dark grey | offwhite | warm grey

> TOP:

MATERIALE > marmo
 FINITURA: Bianco Carrara | Nero Marquina | Botticino Fiorito | Bianco Afyon

> LAVABI SOTTO-PIANO COMPATIBILI:

WHITE 50, BABYLON CERAMIC, ROSE, VICTORIAN

> DIMENSIONE IMBALLO: mm 1400x850x1020H

> PESO: 85 Kg

> DOUBLE VANITY UNIT:

MATERIAL > lacquered wood
 FINISH: dark grey | offwhite | warm grey

> TOP:

MATERIAL > marble
 FINISH: White Carrara | Black Marquina | Botticino Fiorito | White Afyon

> UNDER COUNTERTOP BASINS COMPATIBLE:

WHITE 50, BABYLON CERAMIC, ROSE, VICTORIAN

> PACKAGING SIZE: inch 55 1/8" x 33 1/2" x 40 1/8" H

> WEIGHT: 187 Lbs

N.B. Tutte le misure sono in millimetri/pollici. Questo disegno è di proprietà Devon&Devon. Non può essere riprodotto o trasmesso a terzi senza autorizzazione.

N.B. All measurements are in millimetres/inch. This drawing is property of Devon&Devon. It may not be reproduced or transmitted to third parties without authorization.

Devon&Devon

DOUBLE SEASON

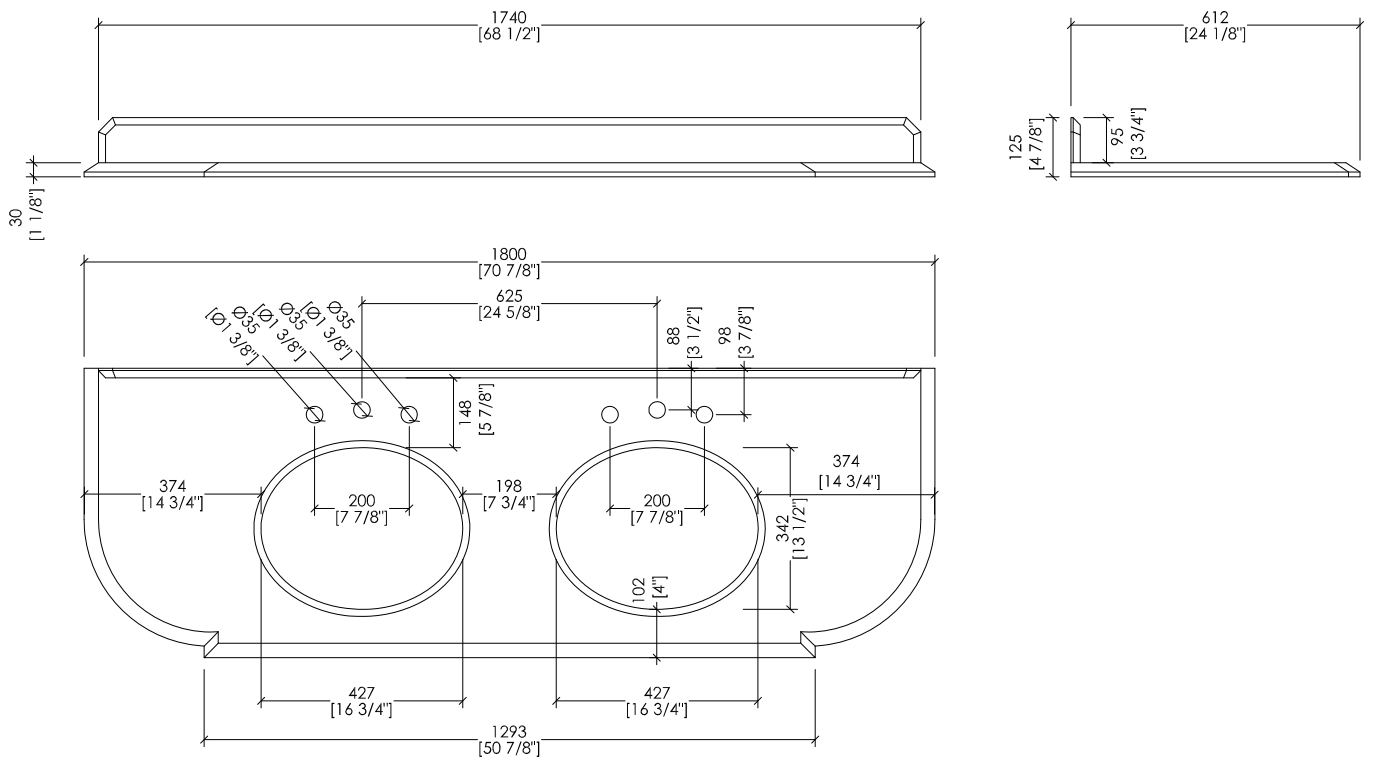

updating 01|2023

> TOP IN MARMO

- > IL MARMO NON È PROTETTO CON IMPREGNANTI.
- > LE QUOTE RELATIVE AI FORI E DISTANZE DEI FORI SONO VALIDE SOLO PER RUBINETTERIE DEVON&DEVON.
- > DIMENSIONI IMBALLO: mm 1960x280x800h
- > PESO: 110 Kg

N.B. Tutte le misure sono in millimetri/pollici. Questo disegno è di proprietà Devon&Devon. Non può essere riprodotto o trasmesso a terzi senza autorizzazione.

> MARBLE TOP

- > MARBLE DOES NOT HAVE A PROTECTED FINISH.
- > THE RELATIVE DIMENSIONS AND DISTANCES BETWEEN TAP HOLES ARE VALID ONLY FOR DEVON&DEVON TAPS.
- > PACKAGING SIZE: inch 77 1/8"x 11"x 31 1/2"H
- > WEIGHT: 243 Lbs

N.B. All measurements are in millimetres/inch. This drawing is property of Devon&Devon. It may not be reproduced or transmitted to third parties without authorization.